

# Site Survey Report

*Prepared for:*

Douglas County School District

For the attention of:

A.J. Willis  
Supervisor of Network Services  
Castle Rock, CO 80104

Tel: 303-387-0392

**SystemSupportSolutions, Inc.**

*Copyright 2006 System Support Solutions, Inc.  
Unauthorized use or reproduction strictly prohibited.*

**Subject:** Certified Free-Space Optics Site Survey Report and Installation Considerations

**Date:** February 21, 2006

**System Support Solutions staff present:** Peter Schoon (virtual)

**Company Staff Present:** A.J. Willis

**Purpose:** LAN Extension for Data + Voice + Video

**Map** of structure locations, link distance and orientation

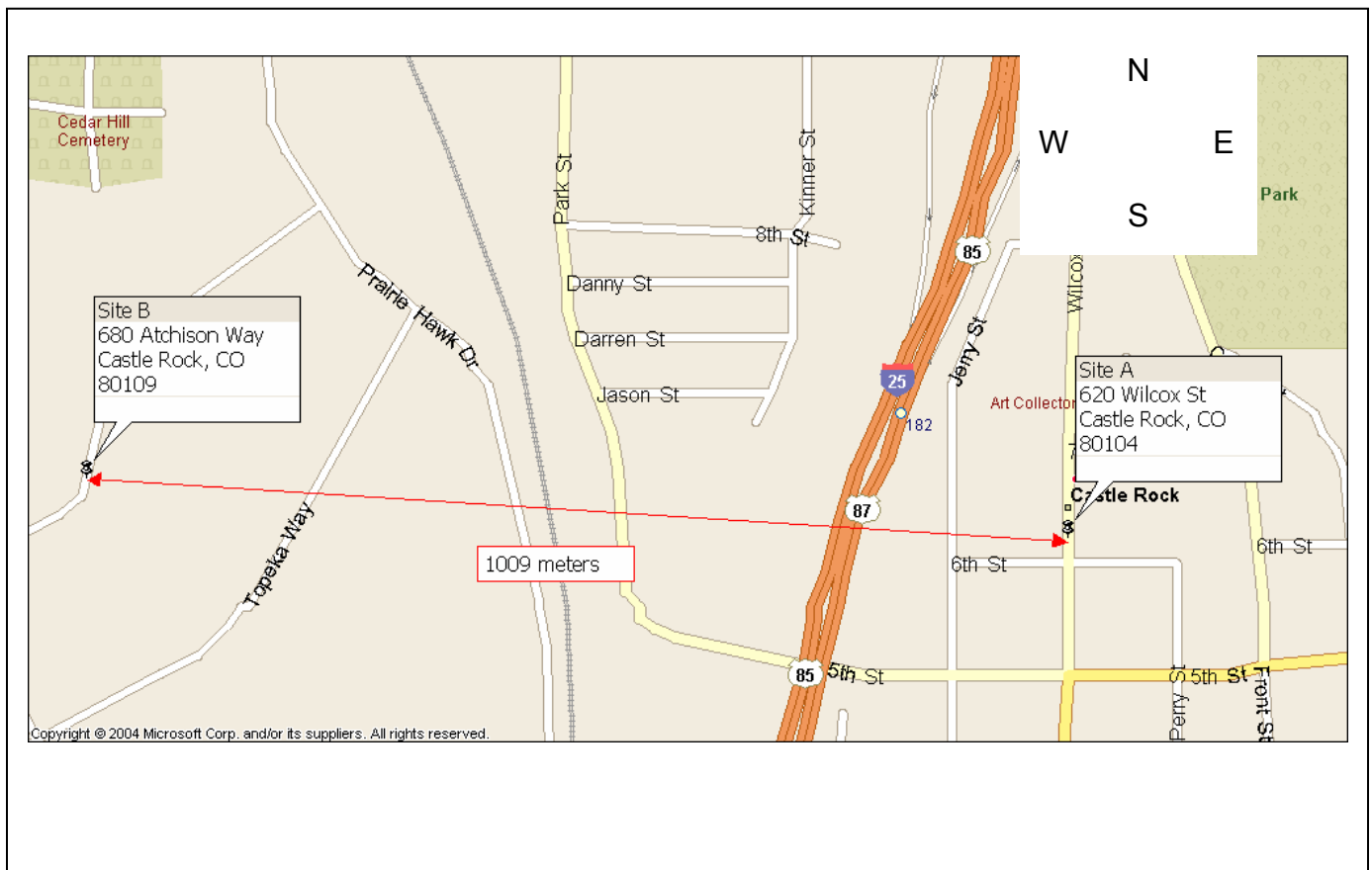

**SystemSupportSolutions, Inc.**

Copyright 2006 System Support Solutions, Inc.  
Unauthorized use or reproduction strictly prohibited.

**Site A**

- DCSD
- 620 Wilcox St.
- Castle Rock, CO

**General Information:**

- Building construction type: Brick
- Height: 3 Story (12m)
- Link head location: Sidewall parapet at roof top level
- Orientation: East-West

**Line of sight:** Visibility between sites is clear with absolutely no obstructions

**Range and Location:**

- Coordinates: 104 51 33.75 West 39 22 33.90 North
- Distance: 1009 meters (as determined by: GPS )
- Number of links: 1
- Additional shelter required: None
- Elevation angle: <10 degrees

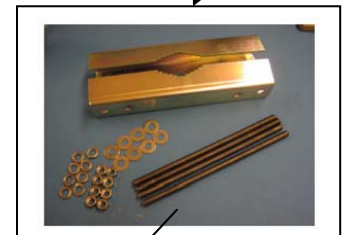
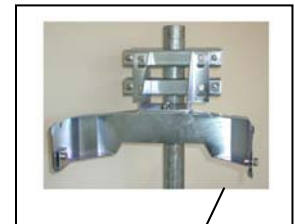
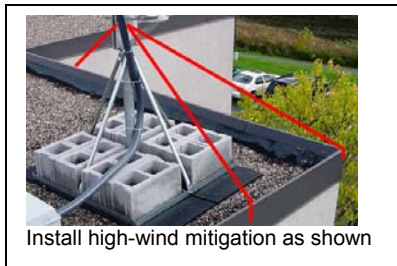

**Mounts:**

- BridgeWave Wall Mount
- Rohn Non-penetrating Mount

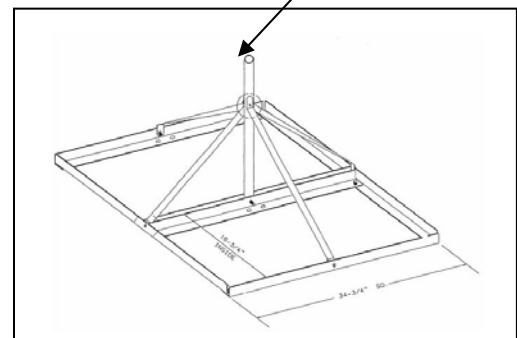

*GE60 Pole Mount Kit Parts List*

Item	Description	Qty.
1	Pole Clamp	4
2	3/8-16x9in Threaded Rod	4
3	3/8 Split Lock Washer	14 (3 spare)
4	3/8 Flat Washer	14 (3 spare)
5	3/8-16 Hex Nut	12 (1 spare)
6	3/8-16 x 3/4 bolts	6 (2 spare)

**Power Source (DCSD to provide):**

The GE60 radio includes a 100-240 VAC power adaptor suitable for indoor operation that converts the AC voltage from the standard electrical outlet in the wall to DC voltage. Our radio requires a minimum of 15.0 VDC (24.0 VDC maximum) up the power cable to the radio to function properly. When planning the cable run from the indoor mounted AC power adaptor to the radio unit, it is critical to use the cable gauge (AWG) indicated below to ensure adequate voltage at the radio. The electrical cable that is used outside the building must be outdoor rated (i.e., weather-protected) providing a single pair of wires necessary to power the equipment. The required DC power cable is 12 gauge, 2 wire (i.e., 12/2) rated for outdoor use.

DC Cable Length	Minimum Cable Size	
	Outside Diameter of DC Cable Jacket (min-max)*	Conductor size
Up to 250 meters	0.17 – 0.45 inches (4.3 – 11.9 mm)	12 AWG

**Table 2-4: Minimum DC Cable Size**

*\*Note: Specification is for the outdoor weather-protected portion of the DC cable entering the radio enclosure. The indoor portion of the DC cable must comply with local building and/or electrical codes in your area.*

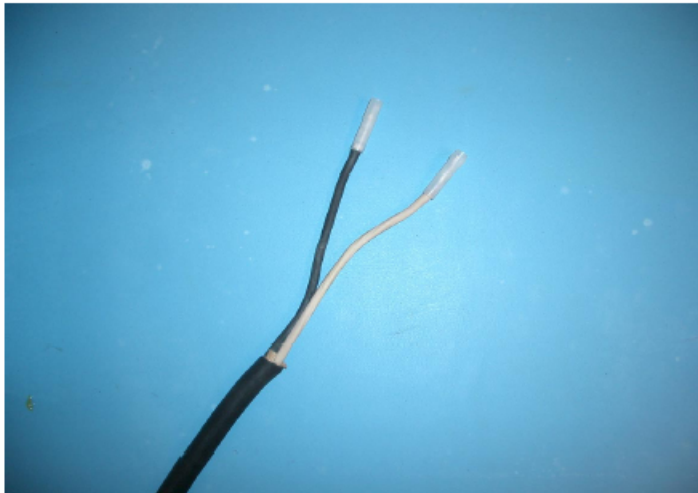

**Figure 2-3 (left) details a standard 12-gauge wire that has been fitted with the power connectors (provided) for the radio’s internal power supply necessary to mate with the provided power cord. A standard crimping/splicing tool (not provided) is required to terminate the power connectors onto the 12-gauge cable required for use with the GE60.**

**Data Cabling (DCSD to provide):**

A multi-mode fiber optic cable is to be run for the rooftop transceivers.

Six (6) strand 850nm mm fiber cable is recommended, 2 for data, 4 for redundancy and equipment diagnostics. The fiber should be terminated with SC connectors.

At the rooftop, the fiber run should be plugged into a 6-strand fiber bulkhead in a rain tight J-box. We will run a 3m SC/LC fiber optic mm patch cable from the patch panel junction box to the transceiver.

**Equipment:**

- Type of unit: BridgeWave GE60X Unlicensed RF
- Communication protocol: Gigabit Ethernet
- Is a new fiber optic interface required for switch?
  - 850nm
  - 1000BSX
- Data Rate: 1.25Gbps Full Duplex

Site B

- DCSD
- 680 Atchison Way
- Castle Rock, CO

**General Information:**

- Building construction type: Steel
- Height: 1 story (4 meters)
- Link head location: Sidewall parapet at rooftop level
- Orientation: East/West

**Line of sight:** Visibility between sites is clear with absolutely no obstructions

**Range and Location:**

- Coordinates: 104 52 15.59 WEST 39 22 32.03 NORTH
- Distance: 1009 meters (as determined by: GPS )
- Number of links: 1
- Additional shelter required: None
- Elevation angle: <10 degrees

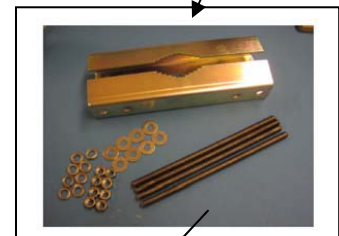
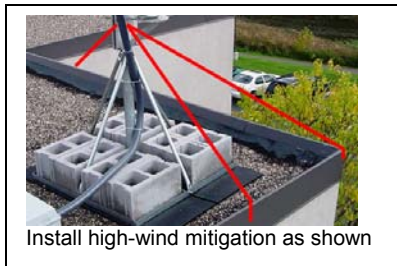

**Mounts:**

- BridgeWave Wall Mount
- Rohn Non-penetrating Mount

*GE60 Pole Mount Kit Parts List*

Item	Description	Qty.
1	Pole Clamp	4
2	3/8-16x9in Threaded Rod	4
3	3/8 Split Lock Washer	14 (3 spare)
4	3/8 Flat Washer	14 (3 spare)
5	3/8-16 Hex Nut	12 (1 spare)
6	3/8-16 x 3/4 bolts	6 (2 spare)

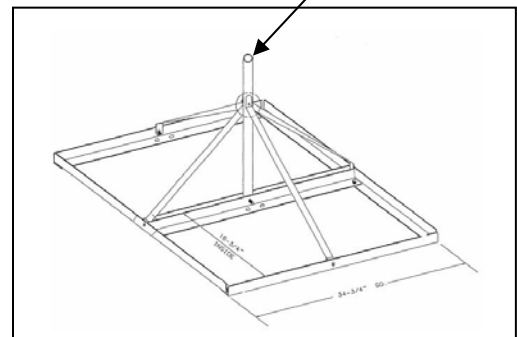

**Power Source (DCSD to provide):**

The GE60 radio includes a 100-240 VAC power adaptor suitable for indoor operation that converts the AC voltage from the standard electrical outlet in the wall to DC voltage. Our radio requires a minimum of 15.0 VDC (24.0 VDC maximum) up the power cable to the radio to function properly. When planning the cable run from the indoor mounted AC power adaptor to the radio unit, it is critical to use the cable gauge (AWG) indicated below to ensure adequate voltage at the radio. The electrical cable that is used outside the building must be outdoor rated (i.e., weather-protected) providing a single pair of wires necessary to power the equipment. The required DC power cable is 12 gauge, 2 wire (i.e., 12/2) rated for outdoor use.

DC Cable Length	Minimum Cable Size	
	Outside Diameter of DC Cable Jacket (min-max)*	Conductor size
Up to 250 meters	0.17 – 0.45 inches (4.3 – 11.9 mm)	12 AWG

**Table 2-4: Minimum DC Cable Size**

*\*Note: Specification is for the outdoor weather-protected portion of the DC cable entering the radio enclosure. The indoor portion of the DC cable must comply with local building and/or electrical codes in your area.*

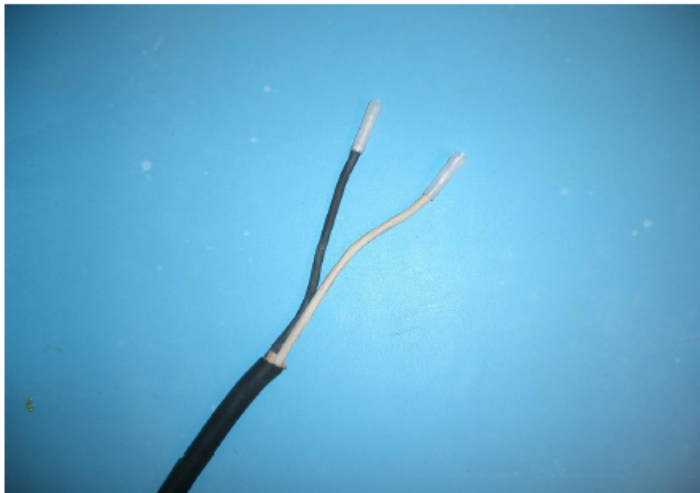

**Figure 2-3 (left) details a standard 12-gauge wire that has been fitted with the power connectors (provided) for the radio’s internal power supply necessary to mate with the provided power cord. A standard crimping/splicing tool (not provided) is required to terminate the power connectors onto the 12-gauge cable required for use with the GE60.**

### **Data Cabling (DCSD to provide):**

A multi-mode fiber optic cable is to be run for the rooftop transceivers.

Six (6) strand 850nm mm fiber cable is recommended, 2 for data, 4 for redundancy and equipment diagnostics. The fiber should be terminated with SC connectors.

At the rooftop, the fiber run should be plugged into a 6-strand fiber bulkhead

in a rain tight J-box. We will run a 3m SC/LC fiber optic mm patch cable from the patch panel junction box to the transceiver.

### **Equipment:**

- Type of unit: BridgeWave Unlicensed GE60X RF
- Communication protocol: Gigabit Ethernet
- Is a new fiber optic interface required for switch?
  - 850nm
  - 1000BSX
- Data Rate: 1.25Gbps Full Duplex

**Site A:**

Mount  
Location

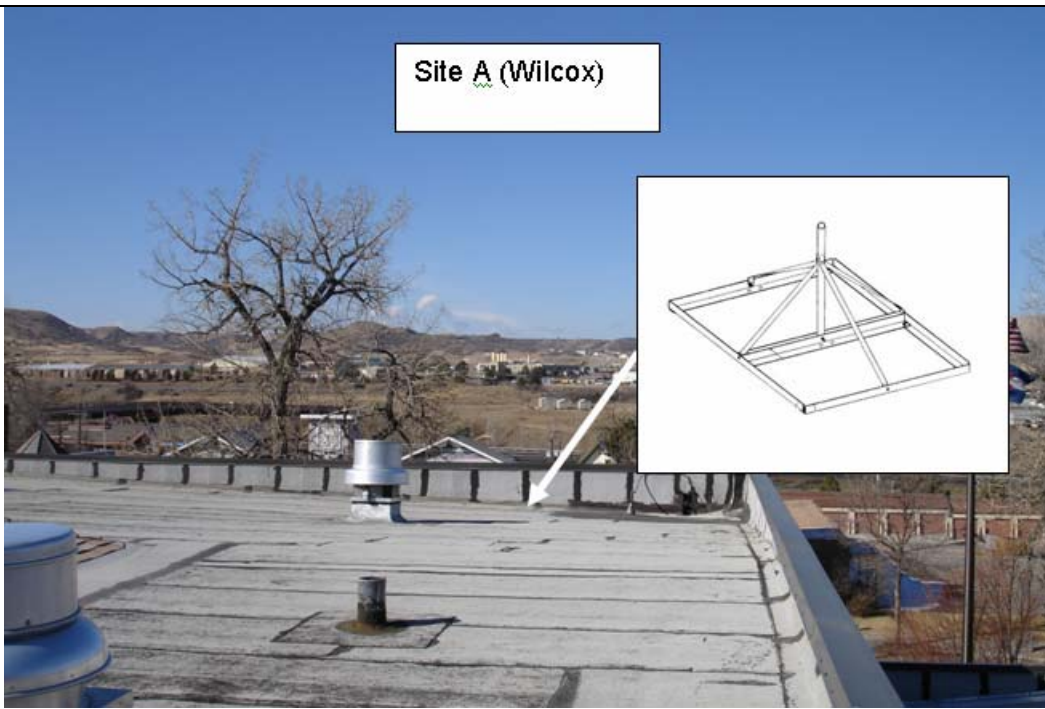

**Site B:**

Mount  
Location

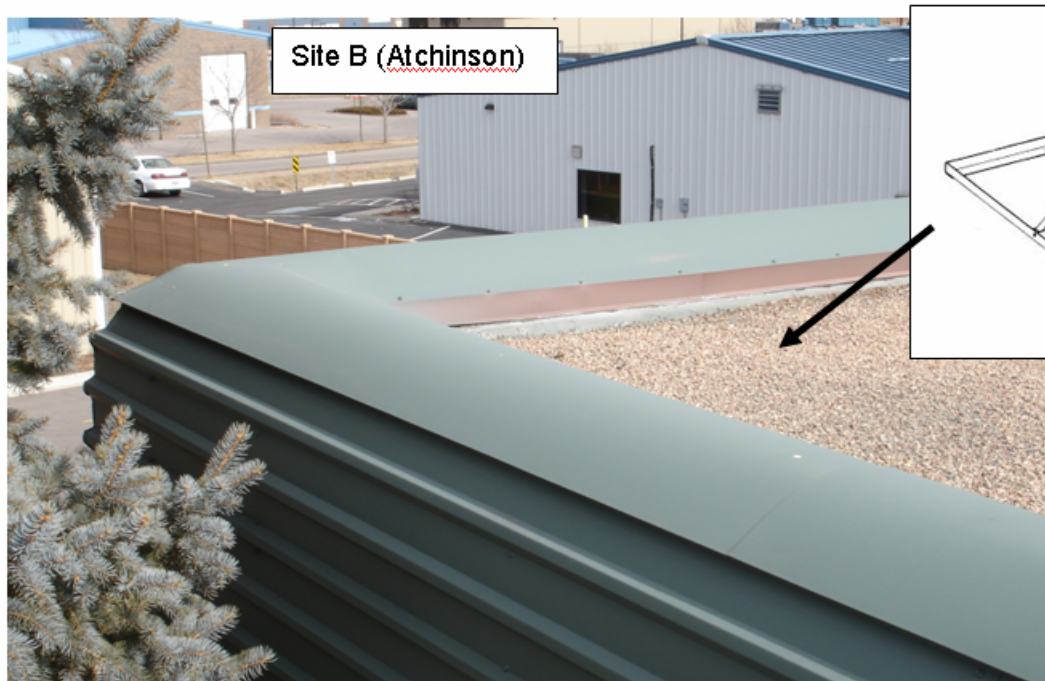

Line of  
Sight  
Path



**Pre-Installation requirements for DCSD:**

**(Note: when completed, please check-off, sign and fax to 952-473-0260, Attn: Peter Schoon)**

- Fiber J-Boxes installed
- Mounts installed per above
- Fiber optic cabling installed
- Fiber optic cabling tested
- 12 AWG DC power cables installed
- 110VAC UPS protected power outlets available indoors for 110VAC/24VDC inverters
- Appropriate switch interfaces installed